

Roll No.

--	--	--	--	--	--	--	--

(Write Roll Number from left side exactly as in the Admit Card)

Signature of Invigilators

1. _____

2. _____

2217

Question Booklet Series

X

PAPER-III

Question Booklet No.

(Identical with OMR Answer Sheet Number)

Subject Code : 22

COMPUTER SCIENCE & APPLICATION

Time : 2 Hours 30 Minutes

Maximum Marks: 150

Instructions for the Candidates

- Write your Roll Number in the space provided on the top of this page as well as on the OMR Sheet provided.
- At the commencement of the examination, the question booklet will be given to you. In the first 5 minutes, you are requested to open the booklet and verify it:
 - To have access to the Question Booklet, tear off the paper seal on the edge of this cover page.
 - Faulty booklet, if detected, should be get replaced immediately by a correct booklet from the invigilator within the period of 5 minutes. Afterwards, neither the Question Booklet will be replaced nor any extra time will be given.
 - Verify whether the Question Booklet No. is identical with OMR Answer Sheet No.; if not, the full set to be replaced.
 - After this verification is over, the Question Booklet Series and Question Booklet Number should be entered on the OMR Sheet.
- This paper consists of seventy-five (75) multiple-choice type questions. All the questions are compulsory. Each question carries *two* marks.
- Each Question has four alternative responses marked: (A) (B) (C) (D). You have to darken the circle as indicated below on the correct response against each question.

Example: (A) (B) (●) (D), where (C) is the correct response.
- Your responses to the questions are to be indicated correctly in the OMR Sheet. If you mark your response at any place other than in the circle in the OMR Sheet, it will not be evaluated.
- Rough work is to be done at the end of this booklet.
- If you write your Name, Roll Number, Phone Number or put any mark on any part of the OMR Sheet, except the space allotted for the relevant entries, which may disclose your identity, or use abusive language or employ any other unfair means, such as change of response by scratching or using white fluid, you will render yourself liable to disqualification.
- Do not tamper or fold the OMR Sheet in any way. If you do so, your OMR Sheet will not be evaluated.
- You have to return the Original OMR Sheet to the invigilator at the end of the examination compulsorily and must not carry it with you outside the Examination Hall. You are, however, allowed to carry question booklet and duplicate copy of OMR Sheet after completion of examination.
- Use only Black Ball point pen.**
- Use of any calculator or mobile phone etc. is strictly prohibited.**
- There are no negative marks for incorrect answers.**

[Please Turn Over]

COMPUTER SCIENCE & APPLICATION

PAPER III

1. Vectored and non-maskable interrupt in 8085 is
 (A) RST 5.5
 (B) RST 6.5
 (C) RST 7.5
 (D) TRAP

2. HOLD/HLDA is related to
 (A) Cycle Stealing
 (B) Handshaking
 (C) DMA
 (D) Reading from and Writing to RAM

3. The following two tables are given:

R	
A	B
a ₁	b ₁
a ₂	b ₁
a ₃	b ₁
a ₄	b ₁
a ₄	b ₂
a ₅	b ₁
a ₁	b ₃
a ₂	b ₃
a ₃	b ₃

S
A
a ₁
a ₂
a ₃

Find $R \div S$ from the following options:

- (A)

B
b ₁
b ₃

 (C)

B
b ₁
b ₂
- (B)

B
b ₁
b ₂
b ₃

 (D)

B
b ₂
b ₃

4. Which is related to animation?
 (A) Multiple frames
 (B) Raster operations
 (C) Morphing
 (D) All of the above

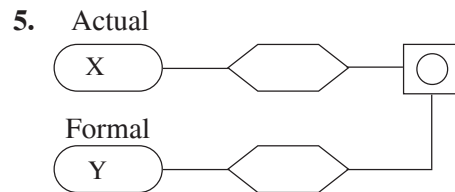

The above diagram represents

- (A) call-by-value
 (B) call-by-name
 (C) call-by-reference
 (D) None of the above
6. In coroutines
 (A) Master-Slave relationship strictly exists.
 (B) Master-Slave relationship can be switched.
 (C) Master-Slave relationship can not be defined.
 (D) None of the above

7. Point out the false one:
- (A) 'IF' is always a two-way branching.
 - (B) Switch-case can be implemented using IF.
 - (C) Switch-case is multiway-branching.
 - (D) Unconditional GOTO is encouraged in structured programming.
8. A linear queue has the following characteristics:
- (A) The queue has to be emptied at regular interval of time.
 - (B) Requires two pointers.
 - (C) The empty condition is $\text{front} = \text{rear}$.
 - (D) All of the above
9. The searching technique that takes $O(1)$ time to find an item is
- (A) Tree search
 - (B) Binary search
 - (C) Linear search
 - (D) Hashing
10. Find out the false one:
- (A) An Object is an instance of a Class.
 - (B) More than one Object can be created from a Class.
 - (C) From a Class another Class can be created.
 - (D) Class is executable.
11. Which of the following software testing methods tests on each smallest unit of software design?
- (A) Smoke testing
 - (B) Integration testing
 - (C) Regression testing
 - (D) Unit testing
12. Under RR-CPU scheduling, we have the following table:
- | <u>Process</u> | <u>Burst Time</u> |
|----------------|-------------------|
| P_1 | 20 |
| P_2 | 3 |
| P_3 | 3 |
- Time quantum = 3 milliseconds. Calculate the average waiting time.
- (A) 6.99 milliseconds
 - (B) 5.00 milliseconds
 - (C) 4.50 milliseconds
 - (D) None of the above

13. In propositional logic, the following rule:

$[(A \rightarrow B) \& (B \rightarrow C)] \rightarrow [(A \rightarrow C)]$ represents

- (A) Modus Ponens
- (B) Modus Tollens
- (C) Hypothetical Syllogism
- (D) Disjunctive Syllogism

14. PROLOG has following characteristics:

- (A) AI Programming Language
- (B) Built-in Inference Engine
- (C) Automatic Backtracking
- (D) All of the above

15. A context-free grammar $G = (V, \Sigma, R, S)$ is said to be in Chomsky normal form if

- (A) $R \supseteq (V - \Sigma) \times V^2$
- (B) $R \subseteq (V - \Sigma) \times V^2$
- (C) $R \subseteq (V - \Sigma) \times V^3$
- (D) $R \supseteq (V - \Sigma) \times V^3$

16. All of the information in a sinusoidal image can be captured by

- (A) The spatial frequency
- (B) The magnitude (+ve or -ve)
- (C) The Phase
- (D) All of the above

17. Regarding UNIX, which one is not true?

- (A) It is multiuser.
- (B) Everything in UNIX is either a file or a process.
- (C) It has no communication facility.
- (D) It is portable.

18. Example of Meta Language—

- (A) BNF
- (B) CBL-Syntax
- (C) Pascal Syntax diagram
- (D) All of the above

19. What is the transmission time for a 2.5 KB message if the bandwidth of the network is 1Gbps?

- (A) 0.030 ms
- (B) 0.020 ms
- (C) 0.050 ms
- (D) 0.010 ms

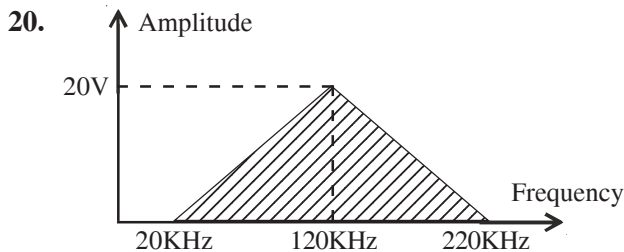

The above signal is

- (A) non-periodic, composite, peak amplitude 20V.
- (B) non-periodic, single, peak amplitude 20V.
- (C) periodic, composite, peak amplitude 20V.
- (D) periodic, non-composite, peak amplitude 20V.

21. The Cache memory concept is based on the principle of

- (A) Memory-Mapped I/O
- (B) Locality of Reference
- (C) I/O mapped I/O
- (D) Look ahead carry

22. Consider a database schema with attributes ABCDEF. One of the given sets of functional dependencies is

$$A \rightarrow BC$$

From $A \rightarrow BC$, we can get $A \rightarrow C$. This is done by

- (A) Augmentation
- (B) Transitive Rule
- (C) Decomposition
- (D) Union

23. Depth sort on priority algorithm is also called

- (A) Direct Clipping
- (B) Canonical Clipping
- (C) Painter's Algorithm
- (D) Orthographic Algorithm

24. If L_1 and L_2 are languages recognised by machines M_1 and M_2 with n and m states respectively, then the machine M that recognises $L_1 \cdot L_2$ will contain the following number of states:

- (A) n
- (B) m
- (C) $n + m$
- (D) nm

25. The regular expression for the set of strings generated by the following CFG:

$S \rightarrow SaS/b$ is given by

- (A) $b(ab)^*$
- (B) $b(a + b)^*$
- (C) $a(a + b)^*$
- (D) $a(ab)^*$

26. First (A)

- (A) is the set of terminals that can start a string that is derivable from A.
- (B) is the set of terminals that can follow an occurrence of A.
- (C) is the set of terminals that can be derived in zero or more steps.
- (D) is the set of non-terminals that is nullable.

27. The mean Bit Error Rate (BER) of a digital channel is

- (A) the probability of a binary bit being corrupted during its transmission across the channel over a defined time interval.
- (B) is a measure of the average number of packets with binary bits.
- (C) the probability of a received packet containing one or more bit errors.
- (D) None of the above

28. A student develops a technique to multiply two 2×2 matrices. The technique requires six multiplications. The complexity of the module that combines the module is $O(n^2)$. Then the recursive equation depicting the complexity of the algorithm is

- (A) $T(n) = 6T(n/3) + O(n^2)$
- (B) $T(n) = 6T(n/2) + O(n^2)$
- (C) $T(n) = 6T(2^n) + O(n^2)$
- (D) $T(n) = T(n/2) + 6 O(n^2)$

29. The binding that binds a function call at runtime is called

- (A) Runtime binding
- (B) Early binding
- (C) Late binding
- (D) Binding by call

30. What is the reason of cohesion in modules?

- (A) Intermodule Relationship
- (B) Intra-module Relationship
- (C) Functional Relationship
- (D) Common Relationship

31. Legacy systems are

- (A) Legal softwares.
- (B) Systems used for long time.
- (C) Systems that have been developed in a long time span.
- (D) Virus-affected system.

32. A module p calls module q and q passes a flag that means “I am unable to complete my task; accordingly write error message ABC123”, then p and q are

- (A) Data coupled
- (B) Content coupled
- (C) Common coupled
- (D) Control coupled

33. Consider the following page trace:

4, 3, 2, 1, 4, 3, 5, 4, 3, 2, 1, 5

The percentage number of page faults that would occur if FIFO page replacement algorithm is used with number of frames = 3, is

- (A) 63%
- (B) 75%
- (C) 83%
- (D) 94%

34. A knowledge base is

- (A) repository of the domain-specific knowledge captured from the human expert.
- (B) repository of the conceptual knowledge in the related field.
- (C) repository of the knowledge derivation rules.
- (D) None of the above.

35. The power of Turing Machine is equivalent to the language of the following grammar:

- (A) Regular grammar
- (B) Context-free grammar
- (C) Unrestricted grammar
- (D) Context sensitive grammar

36. The number of basic variables in an $m \times n$ transportation table are

- (A) $m + n - 1$
- (B) $m + n$
- (C) $m - n + 1$
- (D) mn

37. In UNIX, hidden files can be listed by using

- (A) $ls - lp$
- (B) $ls - lt$
- (C) $ls - tt$
- (D) None of the above

38. The capacity of the memoryless channel capacity specified by

$$\begin{bmatrix} \frac{1}{2} & \frac{1}{4} & \frac{1}{4} & 0 \\ \frac{1}{4} & \frac{1}{4} & \frac{1}{4} & \frac{1}{4} \\ 0 & 0 & 1 & 0 \\ \frac{1}{2} & 0 & 0 & \frac{1}{2} \end{bmatrix} \text{ is given by}$$

- (A) 3/2 bits/symbol
- (B) 5/2 bits/symbol
- (C) 7/2 bits/symbol
- (D) 9/2 bits/symbol

39. Fuzzy intersection of two Fuzzy sets A and B where $A(x) = 0.6$ and $B(x) = 0.4$ is

- (A) 0.4
- (B) 0.6
- (C) 0.5
- (D) None of the above

40. The Fuzzy function $\mu_A(x) = \frac{1}{1 + e^{-\gamma x}}$ is referred

to as

- (A) Gaussian Function
- (B) Logistic Function
- (C) Unimodal Function
- (D) Bimodal Function

41. Let f be a flow in a flow network G with source s and sink t and let (S, T) be a cut of G . Then the netflow across (S, T) is

- (A) $f(S, T) = |f|$
- (B) $f(S, T) = |f + \Delta f|$
- (C) $f(S, T) = |f(S) + f(T)|$
- (D) None of the above

42. The hex contents of two CPU registers in a 16-bit processor are

$$R_0 = 7654$$

$$R_1 = EDCB$$

The following instructions are executed to transfer the contents of these registers to main memory M :

STORE R_0 , ADDR

STORE R_1 , ADDR + 4

M is byte-addressable. Give the contents of the memory locations ADDR+2 and ADDR+6 affected by the above code if the computer is Big-endian.

- (A) 6, D
- (B) 5, E
- (C) 4, B
- (D) 7, C

43. Consider the following zero-address instructions of a zero-address machine:

- PUSH X
- PUSH Y
- Divide
- PUSH C
- PUSH C
- Multiply
- ADD
- POP X

What does the above program compute?

- (A) $Y = (X/Y) + C$
- (B) $X = ((X + C)Y)C$
- (C) $Y = X + C^2$
- (D) $X = (X/Y) + C^2$

44. The ER model is expressed in terms of

- (i) entities
- (ii) relationship among entities
- (iii) the attributes of the entities
- (iv) functional relationship

Which of the following is correct?

- (A) (i), (ii) and (iii)
- (B) (i), (ii) and (iv)
- (C) (i), (iii) and (iv)
- (D) (i) and (ii)

45. Which one of the following is true?

- (A) Distributed database provides faster response to queries compared with centralized database.
- (B) Centralized database provides faster response to queries compared with distributed databases.
- (C) The delay in distributed database response to queries may be unpredictable.
- (D) Availability is more in centralized database than in distributed database.

46. Consider the matrices:

$$M_1 = \begin{bmatrix} 1 & 0 & 0 \\ 0 & -1 & 0 \\ 0 & 0 & 1 \end{bmatrix}$$

$$M_2 = \begin{bmatrix} -1 & 0 & 0 \\ 0 & 1 & 0 \\ 0 & 0 & 1 \end{bmatrix}$$

$$M_3 = \begin{bmatrix} -1 & 0 & 0 \\ 0 & -1 & 0 \\ 0 & 0 & 1 \end{bmatrix}$$

What is correct from the following?

- (A) Matrix M_3 for reflection relative to an axis perpendicular to the xy plane that passes through the co-ordinate origin.
- (B) M_2 for reflection about the line $y = 0$.
- (C) M_1 for reflection relative to the line $x = 0$.
- (D) None of the above

47. Which of the following creates infinite loop in C languages?

- (A) while (; ;)
- (B) for (; ;)
- (C) when (; ;)
- (D) if (; ;)

48. Granularity measures

- (A) relative amount of time spent in computation and communication in parallel system.
- (B) relative amount of time spent in communication and computation.
- (C) amount of time spent in computation on a parallel system.
- (D) None of the above

49. A queue of characters currently contains: a, b, c, d . The following sequence of operations are performed on the queue:

One deletion, addition of x , one deletion, addition of y .

The content of the queue is then put in a CPU register. It is given left circular shift by two characters. What would be the content of the register?

- (A) $cxyc$
- (B) $xydc$
- (C) $cdxy$
- (D) $xycd$

50. Consider the Tower of Hanoi problem with 3 discs. Assuming notation $A \rightarrow B$ indicates that the top most disc from tower A is moved to the top of tower B. Which of the following sequence solves the problem?

- (A) $A \rightarrow C, A \rightarrow B, A \rightarrow C, C \rightarrow B, C \rightarrow A, B \rightarrow C, C \rightarrow A.$
- (B) $A \rightarrow B, A \rightarrow C, B \rightarrow C, C \rightarrow A, B \rightarrow C, C \rightarrow A, A \rightarrow C.$
- (C) $A \rightarrow C, C \rightarrow A, A \rightarrow B, A \rightarrow C, B \rightarrow C, C \rightarrow A, B \rightarrow C.$
- (D) $A \rightarrow C, A \rightarrow B, C \rightarrow B, A \rightarrow C, B \rightarrow A, B \rightarrow C, A \rightarrow C.$

51. What is meant by Weak method in AI?

- (A) Non-search methods
- (B) Methods not exploiting domain knowledge
- (C) Methods requiring less time
- (D) Methods not able to solve all problem instances

52. Consider the following graph for depth-first search starting from node 3. Neighbours of a given node are examined in increasing order. Which of the following is the correct sequence in this search?

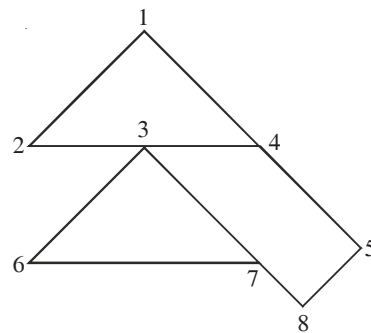

- (A) 31245678
- (B) 32145876
- (C) 32145678
- (D) 36785412

53. What is the number of nodes to be accessed for finding a given key in a B-tree with branching factor 32 and the number of keys equal to 1048575?

- (A) 7
- (B) 4
- (C) 10
- (D) 6

54. An attribute Z is transitively dependent on X if

- (A) $X \rightarrow Y, Y \rightarrow Z$.
- (B) $X \rightarrow Y, Y \rightarrow Z$, but $Y \rightarrow X$ does not hold.
- (C) $X \rightarrow Y, Y \rightarrow Z$, but $Z \rightarrow Y$ does not hold.
- (D) Both (A) and (B)

55. Consider the search problem represented in the following figure, where *a* is start node and *e* is the goal node. The pair [*f*, *h*] at each node indicates the value of the *f* (total estimated cost of reaching a goal from the start node via this node) and *h* (heuristic function: estimated cost of reaching a goal from this node) functions for the path ending at the node. If A* search is used, given this information, what is the cost of edge *c* – *f*?

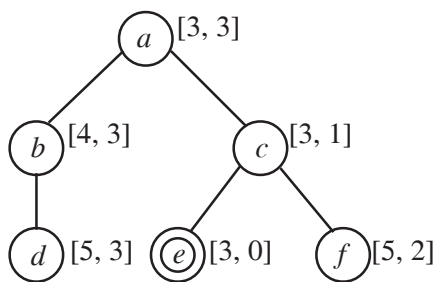

- (A) 1
- (B) 2
- (C) 3
- (D) 4

56. Consider the following MAX-MIN game tree in which the heuristic evaluation scores (in the nodes of the last level) are all from the first player's (MAX) point of view. What is the next move that should be chosen by the first player?

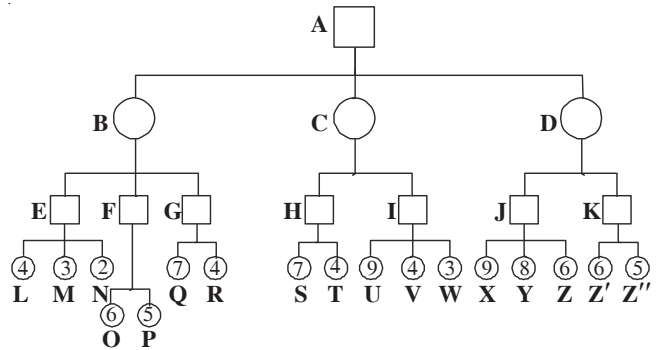

- (A) Node B
- (B) Node C
- (C) Node D
- (D) None of the above

57. Match List I and List II and find the correct answer using the codes given below the lists:

- | | |
|------------------------|-------------------------|
| <i>List I</i> | <i>List II</i> |
| a. Lexical analysis | i. Finite automata |
| b. Code optimization | ii. DAG's |
| c. Code Generation | iii. Syntax trees |
| d. Parsing Programming | iv. Pushdown automation |

Codes:

- | | | | | |
|-----|-----|----|-----|-----|
| | a | b | c | d |
| (A) | iv | ii | i | iii |
| (B) | i | ii | iii | iv |
| (C) | iii | ii | i | iv |
| (D) | iv | i | ii | iii |

- 58.** What is a SPOOLER?
- (A) It is a hardware component.
 - (B) It is a command interpreter.
 - (C) It is a part of a compiler.
 - (D) It is a software component under O.S.
- 59.** In a syntax directed definition, terminals are assumed to have synthesized attributes only because
- (A) the definition does not provide any semantic rules for terminals.
 - (B) the definition and declaration does not provide any expression for non-terminals.
 - (C) values for attributes of terminals are usually supplied by lexical analyzer.
 - (D) None of the above
- 60.** In Bresenham's algorithm error term is initialized to
- (A) 0
 - (B) 1
 - (C) $-1/2$
 - (D) None of the above
- 61.** What is noise in terms of a software development?
- (A) Writing irrelevant statement to the software development in the SRS document.
 - (B) Adding contradictory requirements in SRS document.
 - (C) Writing over-specific requirements.
 - (D) None of the above
- 62.** Using public key cryptography, X adds a digital signature to message M, encrypts and sends it to Y, where it decrypts. Which of the following sequences of keys is used for the operations?
- (A) Encryption: X's private key followed by Y's private key; Decryption: X's public key followed by Y's public key.
 - (B) Encryption: X's private key followed by Y's public key; Decryption: X's public key followed by Y's private key.
 - (C) Encryption: X's public key followed by Y's private key; Decryption: Y's public key followed by X's private key.
 - (D) Encryption: X's private key followed by Y's public key; Decryption: Y's private key followed by X's public key.
- 63.** Which of the following is NOT true with respect to a transparent bridge and a router?
- (A) Both bridge and router selectively forward data packets.
 - (B) A bridge uses IP addresses while a router uses MAC addresses.
 - (C) A bridge builds up its routing table by inspecting incoming packets.
 - (D) A router can connect between a LAN and WAN.

64. The minimum number of non-basic cells in an 8×9 transportation problem is

- (A) 64
- (B) 16
- (C) 17
- (D) 56

65. In solving a maximizing type LPP at some iteration the simplex tableau is found as follows:

			C _j	5	4	6
C _B	B	X _B	b	a ₁	a ₂	a ₃
6	a ₃	X ₃	5	-5	0	1
4	a ₂	X ₂	8	-5/4	1	0
Z _j - C _j				-40	0	0

Then the given LPP

- (A) has no feasible solution.
- (B) has an unbounded solution.
- (C) has alternative optimal solution.
- (D) is inconclusive

66. Consider two variables x and y defined on $X = \{x_1, x_2, x_3\}$ and $Y = \{y_1, y_2\}$ respectively and a proposition

“If x is A then y is B ” where the fuzzy sets A and B are given by $A = 0.5/x_1 + 1/x_2 + 0.6/x_3$ and $B = 1/y_1 + 0.4/y_2$. If a given fact is expressed by the proposition “ y is \hat{B} ” where $\hat{B} = 0.5/y_1 + 0.7/y_2$, then considering Lukasiewicz’s rule of implication a conclusion x is \hat{A} is given by

- (A) $\hat{A} = 0.5/x_1 + 0.5/x_2 + 0.5/x_3$
- (B) $\hat{A} = 0.7/x_1 + 0.7/x_2 + 0.7/x_3$
- (C) $\hat{A} = 0.7/x_1 + 0.5/x_2 + 0.7/x_3$
- (D) $\hat{A} = 0.5/x_1 + 0.7/x_2 + 0.5/x_3$

67. One of the compression techniques in MPEG uses the fact that in most pictures, there is considerable correlation between consecutive frames. This compression is known as

- (A) Spatial compression
- (B) Temporal compression
- (C) Random compression
- (D) Dynamic compression

68. Binary Huffman coding is a

- (A) Suffix condition code
- (B) Prefix condition code
- (C) Both (A) and (B)
- (D) None of the above

69. Wavelet series equation is sum of

- (A) Scaling coefficient
- (B) Detail coefficient
- (C) Span coefficient
- (D) Both (A) and (B)

70. A single-layer perception can solve
- (A) only linearly separable problems.
 - (B) only non-linearly separable problems.
 - (C) both linearly and non-linearly separable problems.
 - (D) some of the non-linearly separable problems.

71. A CPU has 32 bit-memory address and each word has size of 1 byte. Block size is 16 bytes. The size of the cache memory is 256 KB. The cache is organized as a 4-way set associative manner. What is the total amount of extra memory (in bytes) required for the tag bits?

- (A) 2^{20}
- (B) 2^{15}
- (C) 2^{32}
- (D) 2^{24}

72. Suppose a memory system contains the cache, main memory and virtual memory access times as 5 nanoseconds, 100 nanoseconds and 10 milliseconds, respectively. If cache hit rate is 0.8 and main memory hit rate is 0.995, then what is the average memory access time?

- (A) 10024 ns
- (B) 100024 ns
- (C) 124 ns
- (D) 1024 ns

73. The running time of an algorithm $T(n)$, where n is the input size is given by

$$T(n) = 8T(n/2) + qn, \text{ if } n > 1$$

$$= p, \text{ if } n = 1$$

where p, q are constants. The order of the algorithm is

- (A) n^2
- (B) n^n
- (C) n^3
- (D) n

74. A schedule S is recoverable if for each pair of transactions T_i and T_j such that T_j reads an object previously written by T_i , then

- (A) commit operation T_i appears before the commit operation T_j .
- (B) commit operation T_i appears after the commit operation T_j .
- (C) commit sequence is immaterial.
- (D) commit sequence depends upon the context of the schedule.

75. In which case, it is mandatory to provide a destructor in a Class

- (A) for which constructor is defined.
- (B) for which two or more than two objects will be created.
- (C) for which copy constructor is defined.
- (D) whose objects will be created dynamically.

2217-III

X-16

ROUGH WORK